

ZL-7802A Humidity and PID Temperature Controller

Instruction Manual V1.0

Feature

ZL-7802A is an intelligent temperature and humidity controller. IP65 level front panel protection, convenient operation and easy installation. Suitable for control of incubator, climate chamber, warehouse, and so on.







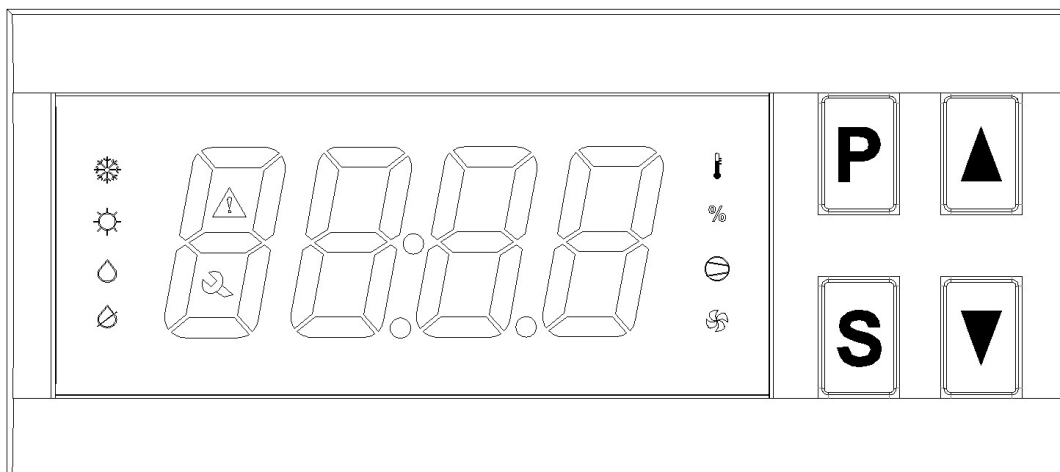



Specification

- ◇ Power supply: 100 ~ 240Vac 50/60Hz
- ◇ Input signal:
 - One humidity and temperature sensor
 - Wire length 1.5 meter
- ◇ Output load: (All based on resistive loads)
 - R1 load, 3A/250Vac
 - R4 and R5 load, 3A/250Vac
 - R2 load, 10A/250Vac (humidity control)
 - R3 load, 5A/250Vac (temperature control)
- ◇ Setting range:
 - Humidity 0 ~ 100% RH, resolution 0.1% RH
 - Temperature -20 ~ 120°C, resolution 0.1°C
- ◇ Sensor accuracy:
 - Humidity 5%
 - Temperature 1%
- ◇ Working environment:
 - Humidity 10 ~ 90% RH without dew
 - Temperature -20 ~ 45°C
- ◇ Device dimension:
 - W78 * H34.5 * D71 mm
- ◇ Drilling size:
 - W71 * H29 mm
- ◇ Case materials: PC + ABS, fire proof
- ◇ Protection level: IP65 (front panel only)

Display



Eco mode: The brightness of display will reduce when no key operation for 30 seconds.

Icon	Function	On	Blinking
	Temp. load (R3)	The load is energized	
	Setting temp.		Setting temp. point
	PID auto tuning		PID auto tuning
	Humidity load (R2)	The load is energized	The load is delay protecting
	Humidify	Humidify mode	Setting humidify point
	Dehumidify	Dehumidify mode	Setting humidify point
	Repair		Fault
	Warning		Warning
	Temp. display	For temp.	Temp. setting / warning
	Humidity display	For humidity	Humidity setting / warning
E1	Fault		Sensor fault
E2	Fault		PID auto tuning fails
THi	Fault		Temp. exceeds up limit
TLo	Fault		Temp. exceeds low limit
HHi	Fault		Humidity exceeds up limit
HLo	Fault		Humidity exceeds low limit
UnL	Hint	Restore to factory default setting	

Key Operation

Temperature and humidity setting

Keep [S] depressed for 3 sec. to enter into temperature and humidity setting. Digits show the set temperature.

Press [P] to switch between humidity & temp. setting. Press [▲] or [▼] to set the value (Fast set by keeping pressed).

Keep [S] depressed for 3 sec. to exit and saving. The set will also be saved if no key operation for 30 sec., then exit.

System parameters setting

Keep [P] depressed for 3 sec. to enter into parameter setting.

If the password is not 0000, digits shows “--0”.

Press [▼] to select the digit of the password, press [▲] to set value (0-9) of the digit.

Press [S] to confirm. If password is correct, show the parameter code.

If the password is 0000, show parameter code.

Press [▲] or [▼] to select the code (see the table below). Press [S] to enter the code setting.

Press [▲] or [▼] to set the value of this code. Press [S] to return.

Keep [P] depressed for 3 sec. to exit and save. The set will also be saved if no key operation for 30 sec., then exit.

Code	Function	Range	Remark	Factory Set
U10	Proportion of PID	0.1 ~ 200		2.6
U11	Integration of PID	1 ~ 5000 sec		500
U12	Differential of PID	0 ~ 1000 sec		50
U13	PID enable	ON/OFF	ON: PID control OFF: Hysteresis control	OFF
U14	Temp. hysteresis	0.1 ~ 20°C	Only effective when U13=OFF	0.1
U15	Temp. calibration	-9.9 ~ +9.9°C		0
U20	Humidity control mode	H/P	H: Humidify mode P: Dehumidify mode	H
U21	Humidity hysteresis	0.1 ~ 20%		2
U22	Delay time for humidity load protection	0 ~ 30 min		0
U23	Humidity calibration	-9.9 ~ +9.9%		0
U40	Timer 1, period 1, time unit	0 ~ 2	0: sec; 1: min; 2: hour	1
U41	Timer 1, period 1, time	1 ~ 9999	R5 on, R4 off	90
U42	Timer 1, period 2, time unit	0 ~ 2	0: sec; 1: min; 2: hour	1
U43	Timer 1, period 2, time	1 ~ 9999	R4 on, R5 off	90
U44	Timer 1, repeat times	0 ~ 9999	0: Timer 1 never stops	0
U45	Timer 2, period 1, time unit	0 ~ 2	0: sec; 1: min; 2: hour	0
U46	Timer 2, period 1, time	1 ~ 9999	R1 on	30
U47	Timer 2, period 2, time unit	0 ~ 2	0: sec; 1: min; 2: hour	1
U48	Timer 2, period 2, time	1 ~ 9999	R1 off	60
U50	Display content alternating time	1 ~ 30 sec	Only when no alarm	5
U60	Timer 2 function mode	1 ~ 2	1: timer only 2: timer + limit_protection	2
U61	Temp. up limit (relative value)	0.0 ~ 120.0°C	Absolute point = (Set-point + U61)	0.2
U62	Temp. low limit (relative value)	0.0 ~ 120.0°C	Absolute point = (Set-point - U62)	57.8
U63	Humidity up limit (relative value)	0.1 ~ 100.0%	Absolute point = (Set-point + U63)	5
U64	Humidity low limit (relative value)	0.1 ~ 100.0%	Absolute point = (Set-point - U64)	60
U99	Password	0000 ~ 9999	0000: skip password	0000



Control Function Instruction

Temperature control

PID control (U13 = ON)

If the default setting is not ideal, it is better to auto tuning the PID parameters.

Auto tuning procedure:

- Set the temperature set point to lower than the temperature of environment.
Cool the heater. Be sure that the equipment inside temperature has been cooled to same as environment.
- Keep \blacktriangle and \blacktriangledown depressed simultaneously for 5 sec. to enter into auto tuning set mode. The “” will blink.
Digits show the power (1-100%) which will supply to the heater during auto tuning.
- Press \blacktriangle or \blacktriangledown to set the power. You may try 50% 1st.
- Press $\llbracket P \rrbracket$ to start heating (auto tuning), the “” is on now.
- You could press $\llbracket \blacktriangledown \rrbracket$ to switch the display between inside temperature and heater power rate.
You could press $\llbracket P \rrbracket$ to stop heating (auto tuning).
If the inside temperature is beyond 100°C, controller will give up the tuning, and show “E2” warning. You could then press $\llbracket P \rrbracket$ to cancel the warning. And re-start the auto tuning from step 2 with lower power rate.
- After the tuning finishes, controller will exist the tuning mode. You could set the set-point, check the PID control.

PID control:

With correct tuning, PID control drives the load based on its forecast ability, so the temperature variation is smaller.

Hysteresis control (U13 = OFF)

When $\text{room_temp.} \leq \text{set_temp.} - \text{【temp. hysteresis, U14】}$, temp. load (R3) will be on.

When $\text{room_temp.} \geq \text{set_temp.}$, temp. load (R3) be off.

Humidity control

Humidify control

When $\text{room_humidity} \leq \text{set_humidity} - \text{【humidity hysteresis, U21】}$, and load (R2) has stopped for **【Delay time for humidity load protection, U22】**, humidity load (R2) will be on.

When $\text{room_humidity} \geq \text{set_humidity}$, humidity load (R2) will be off.

Dehumidify control

When $\text{room_humidity} \geq \text{set_humidity} + \text{【humidity hysteresis, U21】}$, and load (R2) has stopped for **【Delay time for humidity load protection, U22】**, humidity load (R2) will be on.

When $\text{room_humidity} \leq \text{set_humidity}$, humidity load (R2) will be off.

Load delay protection

After powered supplied, humidity load (R2) needs the time of **【Delay time for humidity load protection, U22】** to start.

After humidity load (R2) is off, it needs the time of **【Delay time for humidity load protection, U22】** to start again.

Timer 1 control (R4, R5)

During period 1, R5 on, R4 off.

During period 2, R4 on, R5 off.

If the repeat times (U44) is set to 0, it will repeat infinitely. Or the timer will stop after the times of full period = U44.

Timer 2 control (R1)

During period 1, R1 on.

During period 2, R1 off.

Temperature and humidity limit protection

U60 = 1, R1 is timer output only.

U60 = 2, R1 is timer output + limit protection output

When temperature or humidity is beyond their limit (U61, U62, U63, U64), R1 will be on.

Sensor

When the sensor is broken, controller shows "E1", humidity and temperature loads will be off.

When the display value is different from real value, it can be calibrated (U15, U23).

Do not plug in, or out the sensor when the power is supplied.

Factory setting:

Keep **【P】** and **【▲】** depressed simultaneously for 5 sec., the device displays "UnL", press **【▼】** twice, the controller will reset all parameters to factory default settings.

Installation Procedure

Insert the controller into hole (step one) Slide the bracket to fix the device (step two)

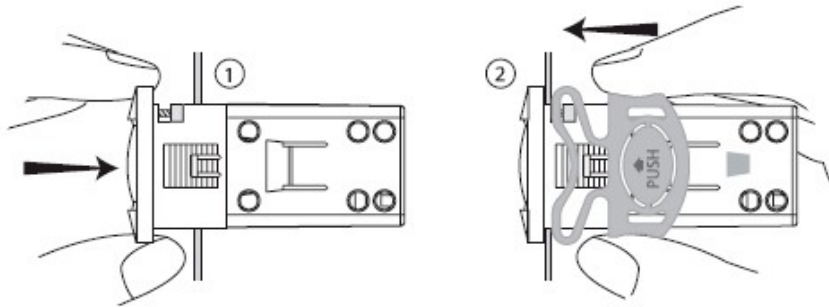

Warning



- Electrical wiring must be manipulated by certified electrician.
- Wrong power supply may damage the device and system seriously.
- Try with effort to layout the sensors and switches line apart from inductive load lines and power supply lines. The sensors and switches lines are not allowed go with the power supply lines and inductive load lines in a same pipeline, and are not allowed to pass near the contactor, breaker and the similar.
- Reduce the length of sensors' wiring if possible. Avoid forming a spiral shape near the power devices.
- Avoid direct contact with the internal electronic components.
- After finishing and checking the electrical wiring, before connecting them to the device, please follow this instruction: Pay attention the "electrical wiring diagram" below, wrong connection possibly damages the device and the system, and may be dangerous to the user. All security and protecting device for the equipment are necessary. They are very important to protect the equipment, and the user's safety.

Electrical Wiring Diagram

